

Underfloor Sump Baufix 50

Application

The Baufix 50 is a compact underfloor sump designed for the installation in basements or cellars. Together with the submersible sump pump U 3 KS Niro it is suitable for the drainage of domestic waste water from washbasins, sinks, showers and washing machines in cellars or lavatories. A floor drain in the cover of the sump protects against larger inundation at the place of installation. The application as a collecting tank for sewage from toilets is not permitted.

The pressure resistant plastic tank is placed without formwork into the concrete base. Only the inlet pipes need to be connected and the tank can be encased with concrete. Installation in areas subject to ground water is not permitted because a sump/concrete connection cannot be sealed against pressing water.

The chamber neck with its adjustable and rotating cover allows an optimum level compensation at the building site. The depth of installation can be adjusted to a range of 45-71 cm. The position of the two inlets enables very low entry into the chamber.

The mounted swing-type check valve prevents a reflux of the waste water from the pressure pipe into the tank. The standard air trap stops annoyance caused by bad smell.

The quick action hose clamp in the sump guarantees ease of installation and maintenance of the pump. For lower installation and a wider range of pumps, we recommend our Baufix 100 and Baufix 200.

This unit complies to the EN 12050.

The minimum flow velocity in the pressure piping must be 0,7 m/s according to EN 12056. This data is represented in the Q/H performance curve as a limit of application.

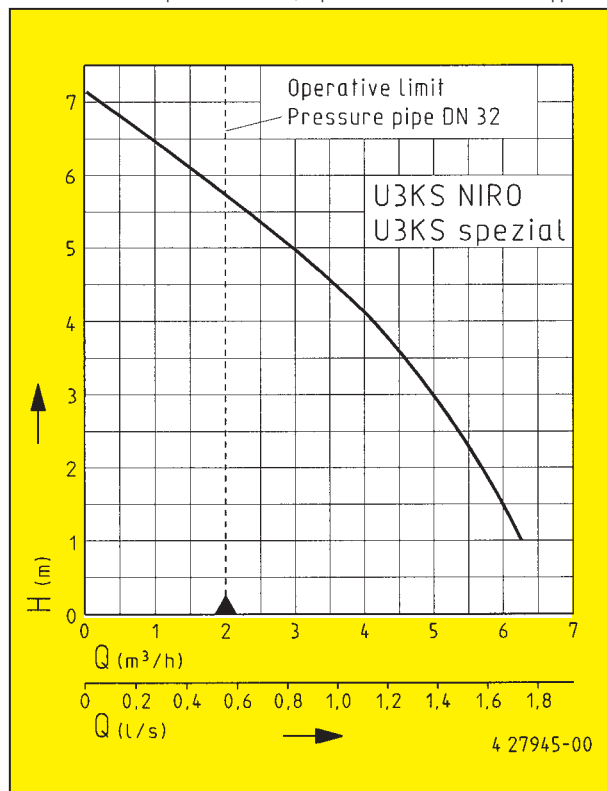

We reserve the right to change specifications without notice.
Pump performance is subject to ISO 9906 tolerances.



- ▶ Air trap
- ▶ Floor drain
- ▶ Integrated sump extension
- ▶ Complete pressure pipe in the tank
- ▶ Mounted swing-type check valve
- ▶ Level-compensating frame
- ▶ Quick-locking of the pump
- ▶ 2 combination inlets DN 50/100



Underfloor sump

Type	max. h x w x l	Weight	Code No.
Baufix 50-tank with floor drain and cover, without pump	575 x 405 x 380 mm	11,5 kg	09335

Performances

Type	Delivery head H [m]	1	2	3	4	5	6
U 3 KS NIRO	Flow rate Q [m ³ /h]	6,5	5,5	5	4	3	1,5
U 3 KS spezial		6,5	5,5	5	4	3	1,5

Electrical data

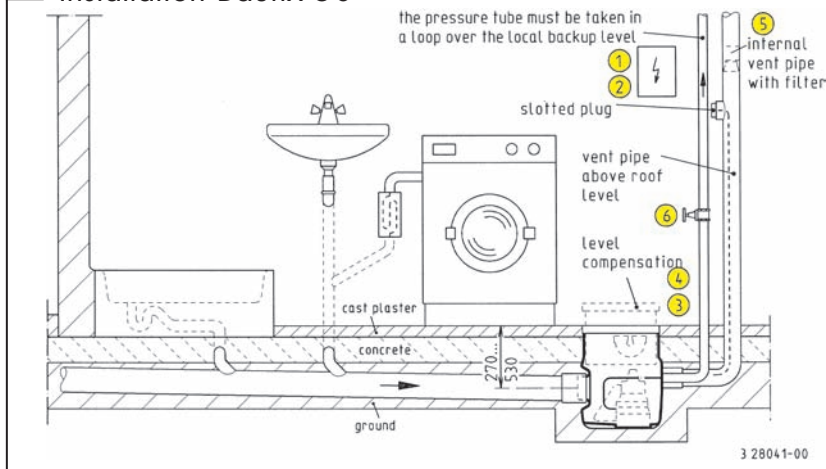

Baufix 50-tank alternative with type	Type of current	Voltage Volt	Motor rating kW P ₁ P ₂	RPM min ⁻¹	F.L.C. Amp.	Motorprotection	Plug
U 3 KS NIRO	1-phase	1/N/PE~230	0,32 0,20	2720	1,4	incorporated	Safety-
U 3 KS spezial	1-phase	1/N/PE~230	0,32 0,20	2720	1,4	in motor	Safety-

Installation Baufix 50

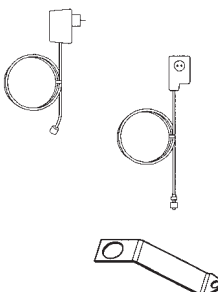

In case of installation beneath the backpressure level the pressure tube must be taken in a loop over the local backup level acc. to EN 12056. Besides, it must be secured with EN-12050-4 proofed swing-type check valve. Additionally we recommend an alarm system.

Accessories

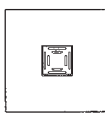
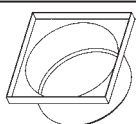
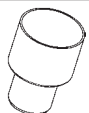
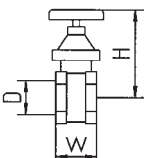
		Code No.						
	1 Alarm system , mainsdependent, with volt-free contact	20198						
	Alarm system for washing machines AWR 3 with reed switch, separate, mains operated, 3 m cable	25092						
	Alarm system for washing machines AWO (Plug housing – for alarm forwarding in case of several washing machines)	25233						
	Fastener for alarm system	28191						
	2 Rechargeable battery for off the line operation of the alarm system	07562						
	3 Cover plate to be tiled with floor drain and syphon	24024						
	4 Cover frame , Niro	28118						
	5 Ventilation , special filter c/w casing	27484						
	6 Stop valve 1 1/4"	<table border="1"> <thead> <tr> <th>H</th> <th>W</th> <th>D</th> </tr> </thead> <tbody> <tr> <td>110</td> <td>max.60</td> <td>1 1/4"</td> </tr> </tbody> </table>	H	W	D	110	max.60	1 1/4"
H	W	D						
110	max.60	1 1/4"						

Mounting arrangement

Floor level compensation

The cover with round throat shoulder in the shaft opening can be aligned vertically and rotationally. Sealing between tank and cover is achieved by a round sealing cord. This makes it possible to adjust the Baufix to the effective top edge of floor coverings laid later e.g. tiles.

Air trap

An air trap is provided as standard for the floor drain. The necessary syphon components form part of the scope of supply.

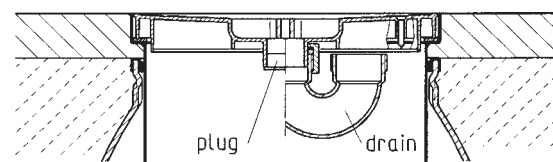
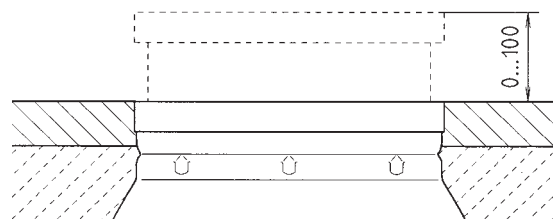

4 22314-03

Technical data

Tank

Water-tight PE-tank (40-55 l) with two combination inlets (DN 50 as sleeve/DN 100 as branch) for a space-saving connection, a tank venting facility (DN 70) and a pressure pipe DN 32 (for 40 mm PVC pipe), integrated sump extension, level-compensating plastic frame, tight plastic cover (screw fitted) and tight floor drain.

All junctions tank/cover frame and cover frame/cover plate are fitted with seals.

Installation

Place the tank into the prepared pit or existing sump, adjust the frame to the desired position and connect the pipes. Afterwards encase the sump with concrete flush with top edge. Insulation, floor pavement and flooring material will be leveled out by the height-adjustable

cover. Connect the low level float and pressure pipe parts to the pump and join it with the plastic pipe connection to the pre-assembled swing-type check valve. Thread the pump's power cable through the vent pipe up to the T-piece. The outlet can be sealed with the slotted plug. If a ventilation via roof is impossible the special ventilation (accessory/installation drawing) can be used.

Attention: It is not necessary to cut off the plug!

Delivery

Plastic tank for application of a EN 12050 inspected pump with level-compensating plastic cover, level-compensating sump extension, cover frame with cover plate, air trap for floor drain, parts for sump assembly and mounted swing-type check valve, special float for low switching points, pluggable seal DN 50, stopper for cable pipe (without pump).

