

Application

Submersible sewage pumps with the cutting system MultiCut are used as non-moving appliances in pressure drainage systems for discharge in sparsely populated areas or for single buildings. They are suitable for pumping domestic waste waters with the usual additions (as specified in DIN 1986 part 3).

For pumping from ducts that are connected to the public sewer system ex-proof submersible pumps of the series UFK have to be used. Due to the upstream cutting system the pressure line manufactured in DN 40 - without cutting system minimum DN 80 - can be routed parallel to the terrain. Operating conditions up to 40 °C temperature of material to be pumped.

Submerged motor: Continuous operation (S1)

Emerged motor: Intermittant operation (S3)

(for example 20 % = 2 min. operation, 8 min. pause)

The MultiCut System

The liquid flows into the impeller through a rigid, perforated cutter plate in which apertures are tapered to improve the suction performance. The sharpened three bladed cutter, rotating in front of the inlet, shears any solids present. The impeller then passes them through a counterflow system in the wear plate, thence into the volute casing and out through the pump discharge. The cutter plate rejects any material such as stones or metal that it is unable to cut. The combined cutting and pumping system gives trouble-free, low-cost sewage disposal even with difficult ground conditions.

The minimum flow velocity in the pressure piping must be 0,7 m/s according to EN 12056. This data is represented in the performance curve as a limit of application.

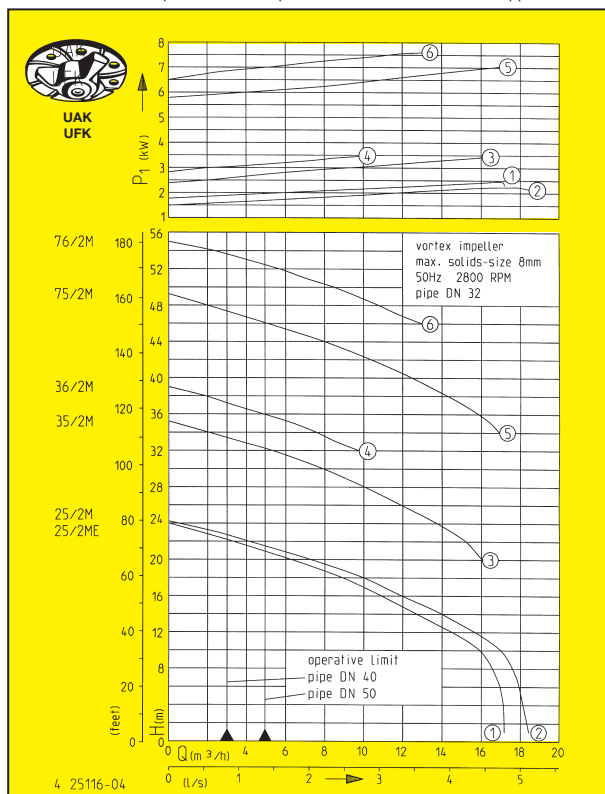

UFK 25/2 M

▶ Cutter with effect on suction performance

▶ Plug-in cable connection (UAK/UFK 25...-36/2M)

▶ Outlying adjustable cutting system

▶ Controllable oil chamber

▶ SiC mechanical seal independent of sense of rotation

▶ Moisture sealed cable inlet

▶ Z-53.2-348 (UFK 25...-76/2M)



We reserve the right to change specifications without notice. Pump performance is subject to ISO 9906 tolerances.

Submersible sewage pumps

Type	Height/Width (max.)	Cable length	Discharge branch	Weight	Code No.
UAK 25/2 ME*	390 x 330 mm	10 m	DN 32	37 kg	9843
UAK 25/2 M	355 x 330 mm	10 m	DN 32	37 kg	9809
UAK 35/2 M	390 x 330 mm	10 m	DN 32	41 kg	9806
UAK 36/2 M	390 x 330 mm	10 m	DN 32	41 kg	9907
UAK 75/2 M	520 x 430 mm	10 m	DN 32	90 kg	9912
UAK 76/2 M	520 x 430 mm	10 m	DN 32	90 kg	9262
UFK 25/2 ME*	390 x 330 mm	10 m	DN 32	37 kg	9742
UFK 25/2 M	355 x 330 mm	10 m	DN 32	37 kg	9810
UFK 35/2 M	390 x 330 mm	10 m	DN 32	41 kg	9807
UFK 36/2 M	390 x 330 mm	10 m	DN 32	41 kg	9908
UFK 75/2 M	520 x 430 mm	10 m	DN 32	90 kg	9913
UFK 76/2 M	520 x 430 mm	10 m	DN 32	90 kg	9263

* see technical advice

Performance

Type	Delivery head H [m]	6	9	12	15	18	21	25	28	32	34	36	40	44	46	48	50	52	54
UAK/UFK 25/2 ME	Flow rate Q [m ³ /h]	17	16	15	12	9	5												
UAK/UFK 25/2 M		18	17	16	13	10	6												
UAK/UFK 35/2 M		-	-	-	-	-	16	13	10	6									
UAK/UFK 36/2 M		-	-	-	-	-	-	-	-	10	8	5							
UAK/UFK 75/2 M		-	-	-	-	-	-	-	-	-	17	17	13	8	5	2			
UAK/UFK 76/2 M		-	-	-	-	-	-	-	-	-	-	-	-	13	11	9	6	3	

Electrical data







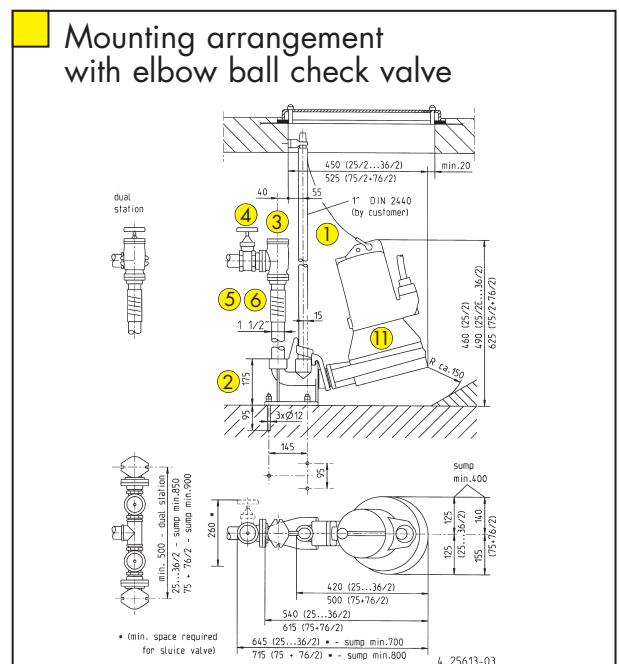
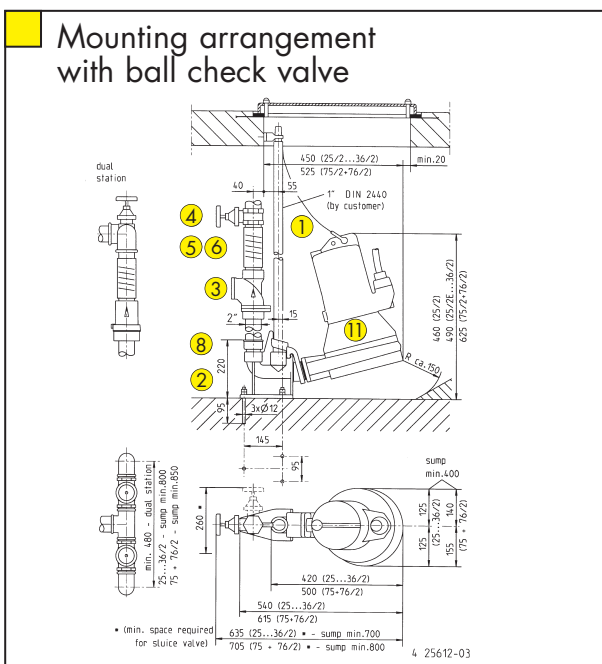

Type	Voltage Volt	Motor rating kW P ₁	P ₂	S3 %	F.L.C. Amp.	Built-in motor-protection	RPM min ⁻¹	Cable	Safety-fuse min.
UAK/UFK 25/2 ME**	1x 230	2,70	2,04	35	12,0	thermostat	2776	H07 RN-F 6G 1,5	16 A
UAK/UFK 25/2 M	3x 230/400	2,60	2,10	40	7,6/4,4	thermostat	2860	H07 RN-F 6G 1,5	10 A
UAK/UFK 35/2 M	3x 230/400	3,70	3,04	40	11,5/6,6	thermostat	2895	H07 RN-F 6G 1,5	10 A
UAK/UFK 36/2 M	3x 230/400	3,70	3,04	40	11,5/6,6	thermostat	2895	H07 RN-F 6G 1,5	10 A
UAK/UFK 75/2 M	3x 400/690	7,70	6,60	30	13,2/7,7	thermostat	2920	H07 RN-F 10G 2,5	20 A***
UAK/UFK 76/2 M	3x 400/690	7,70	6,60	30	13,2/7,7	thermostat	2920	H07 RN-F 10G 2,5	20 A***

** operation only possible with control unit AD 12 ExME

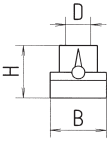
***value for Y/Δ-starting

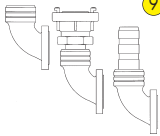
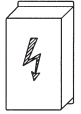

Accessories

		Code No.	25/2 ME	25/2 M	35/2 M	36/2 M	75/2 M	76/2 M										
	1 Chain , DIN 766, weight-bearing capacity 5 x 18,5, length 2,5 m, 2 rings 320 kg 19189 5 x 18,5, length 5,0 m, 2 rings 320 kg 423 Stainless steel (1.4401), 4 x 16,0, length 2,5 m, 5 rings+1 shackle 200 kg 23986 Stainless steel (1.4401), 4 x 16,0, length 5,0 m, 8 rings+2 shackles 200 kg 24934 Hoist (not for chains in stainless steel) 21394		•	•	•	•	•	•										
	 2 Guide rail system GR 35 , 1½" inside thread (see mounting arrangement) 14094		•	•	•	•	•	•										
		3 Swing-type check valve 1½" (DN 40), PN 4 317 EN 12050-4 2" (DN 50), PN 4 326	<table border="1"> <thead> <tr> <th>H</th> <th>B</th> <th>D</th> </tr> </thead> <tbody> <tr> <td>150</td> <td>120</td> <td>1½"</td> </tr> <tr> <td>150</td> <td>120</td> <td>2"</td> </tr> </tbody> </table>	H	B	D	150	120	1½"	150	120	2"	•	•	•	•	•	•
		H	B	D														
		150	120	1½"														
150	120	2"																
Ball check valve 2" (DN 50), PN 6 9857 EN 12050-4 (without illustration)	185 155 2"	•	•	•	•	•	•											
Elbow ball check valve 1½" (DN 40), PN 6, EN 12050-4 22442		•	•	•	•	•	•											
	4 Stop valve 1½" (DN 40), PN 16 11837 2" (DN 50), PN 16 11838	<table border="1"> <thead> <tr> <th>H</th> <th>L</th> <th>D</th> </tr> </thead> <tbody> <tr> <td>125</td> <td>max.60</td> <td>1½"</td> </tr> <tr> <td>140</td> <td>max.67</td> <td>2"</td> </tr> </tbody> </table>	H	L	D	125	max.60	1½"	140	max.67	2"	•	•	•	•	•	•	
	H	L	D															
125	max.60	1½"																
140	max.67	2"																
5 Elastic connection 1½" (DN 40), PN 4 20368 2" (DN 50), PN 4 17194	<table border="1"> <thead> <tr> <th>H</th> <th>D inside</th> </tr> </thead> <tbody> <tr> <td>120</td> <td>50</td> </tr> <tr> <td>150</td> <td>63</td> </tr> </tbody> </table>	H	D inside	120	50	150	63	•	•	•	•	•	•					
H	D inside																	
120	50																	
150	63																	
	6 Hose band clamp 1½" 3571 Hose band clamp 2" 3572		•	•	•	•	•	•										
	 7 Pump base M (without illustration) 20980 Pump base M 220 22302 Holder in connection with static air level control 23100		•	•	•	•	•	•										
	8 Reducing socket 1½"-2", for guide rail system GR 35 18388 1¼"-1½", for pressure outlet 10152 1¼"-2", for pressure outlet 14274		•	•	•	•	•	•										
		9 Pipe connection 1¼" (inside thread), for transportable use 16870	•	•	•	•	•	•										
		Coupling connection size C, for transportable use 14076	•	•	•	•	•	•										
Hose tail bend ø 42, for transportable use 14077		•	•	•	•	•	•											
	10 Electrical connection Single unit AD 12 ExME* 24066 + Softstarter for control unit 24138 AD 46 ExM* 19749 AD 46 MP SM* 27119 AD 610 ExM* 19953 AD 610 MP SM* 27120 AS 610 ExM* 21998 Duplex unit BD 46 ExM* 23234 BD 46 MP SM* 27153 BD 610 ExM* 23235 BD 610 MP SM* 27154 BS 610 with accessories		•	•	•	•	•	•										
	* including static air level control																	
	 Rechargeable battery for off the line operation of the alarm system (for control units MP SM please order two pieces) 7562		•	•	•	•	•	•										
		11 Seal leak detector DKG (for UAK...) 252 Seal leak detector DKG-Ex (for UFK...) 249		•	•	•	•	•										
				•	•	•	•	•										

Technical data

Pump

Vertical, single-stage, submersible, pump case with horizontal discharge, open impeller, adjustable MultiCut cutting system.

Bearings

Common shaft for pump and motor, grease-packed ball bearings.

Seal

Silicon carbide mechanical seal independent of sense of rotation, oil chamber and artificial carbon mechanical seal or duplex rotary shaft seal as secondary seal, safe to run dry.

Motor

Submersible, insulation class F, enclosure IP 68, protected by winding thermostats, automatic activation through control unit only or – up to 3,2 kW three-phase current – by CEE-plug with motorprotection (upon request), UFK types tested by PTB, type of protection Ex II 2 G EEx d IIB T4.

Materials

Pump and motor case as well as impeller in grey cast iron GG (impeller 75/2 and 76/2 in spheroidal graphite iron), corrosion protected shaft no contact with pumped liquid, stainless steel hardened (HRC 57) cutting system, flexible rubber sheathed cable.

Scope of supply

Effluent pump UAK or sewage pump UFK with explosion protection acc. to EN 12050 with shackle and 10 m cable, without plug, without pump base.

Special technical note for UAK/UFK 25/2 ME

Since the rated output of the a.c. motor exceeds 1.4 KW, the permission of the local power supply organisation must be obtained before ordering and commissioning.

Softstarting device (for UAK/UFK 25/2 ME only)

The softstarting device is a resistive starting unit with built-in overheating protection in order to reduce the starting current to approx. 33 A. The max. switching frequency is 10/hour at 40 °C of ambient temperature.

The installation of this componentry into the control panel AD 12 ExME takes place in the factory when ordering. A later installation is not possible.

