

## Application

The Hebefix 100 floor-mounted sump is a water pumping station for lifting sewage-free and industrial/commercial effluents up to 104° F (40° C). The version Hebefix 100 H is resistant against waste water up to 176° F (80° C). It consists of a free-standing plastic tank (approx. 75 ltr) with four combination inlets for 50 mm or 110 mm o.d. PVC pipes. The internal tank discharge pipe kit is provided and suitable for fitting for right or left outlet, (connection R 1½").

Pump selection is made according to the amount of waste water to be handled: the U 3 KS NIRO and U 5 KS NIRO as cellar drainage for one-family houses, the U 6 KS NIRO ES/DS for larger waste water amounts, pumps of the US-series for apartment buildings and commercial use. The level control can be optionally adjusted and the residual water volumes reduced by use of a special float (see accessories). The resistance of the materials must be checked in advance for commercial applications.

The Hebefix is ideal for secondary ground-level installation. The Hebefix can be installed in any position – even below the local backup level to prevent flooding – without expensive masonry work and without excavating the floor. Wash basins, washing machines or dishwashers as well as shower trays installed at ground level (in combination with a U 3 KS NIRO or U 6 KS with special float) can be connected without any problem.

Connection to a ventilation pipe prevents odours. If the tank is ventilated via the area of installation, the activated carbon filter of the Hebefix 100 reduces unpleasant odour. It is recommended to install an alarm system. This provides warning if the water level in the tank exceeds the permissible limit.

We reserve the right to change specifications without notice. Pump performance is subject to ISO 9906 tolerances.

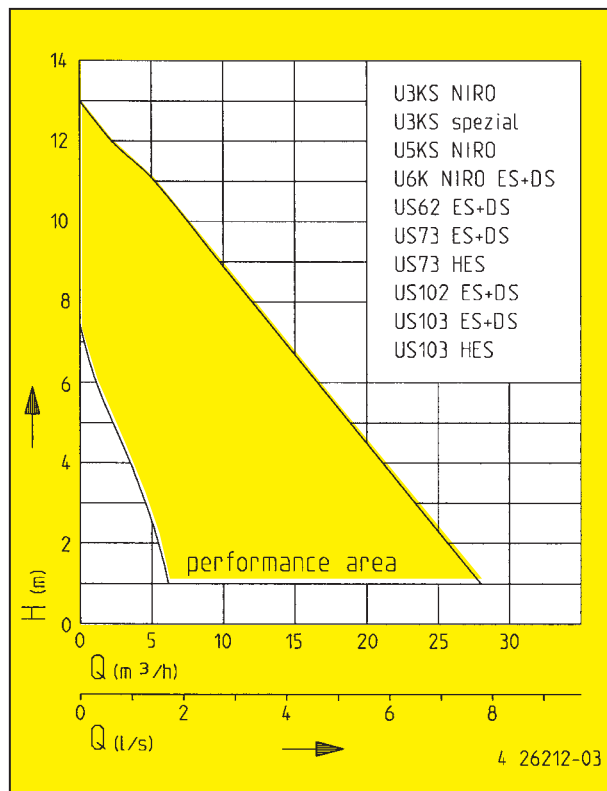

Hebefix 100 with US pump

- ▶ Selectable side of discharge
- ▶ Alarm system available
- ▶ Hot water up to 176° F (80° C)
- ▶ Swing-type check valve
- ▶ Activated carbon filter (Hebefix 100)



## Floor-mounted sump

Type	Height x Width x Depth	Connection	Weight	Code No.
Hebefix 100-tank without pump	500 x 570 x 390 mm	4 x 50 mm 4 x 110 mm	9,4 kg	<b>09319</b>
Hebefix 100 H-tank without pump (resistant against hot water up to 176 °F/80 °C)	500 x 570 x 390 mm	4 x 50 mm 4 x 110 mm	12,3 kg	<b>09348</b>

## Performance

Type	Delivery head H [m]	1	2	3	4	5	6	7	8	9	10	11	12
U 3 KS NIRO	Flow rate Q [m³/h]	6,5	5,5	5	4	3	1,5						
U 3 KS spezial		6,5	5,5	5	4	3	1,5						
U 5 KS NIRO		11	10,5	9	7,5	6,5	4,5	2,7					
U 6 K NIRO ES		16	14,5	13	11	9,5	7	4,5	2				
U 6 K NIRO DS		17	16	15	13,5	11,5	10	7,5	4	0,5			
US 62 ES		19	17	15	12	10	8	6	4	2			
US 62 DS		22	20	17	15	12	10	8	6	4			
US 73 ES/HES		19	17	15	12	10	8	6	4	2			
US 73 DS		22	20	17	15	12	10	8	6	4			
US 102 ES/DS		28	26	23	21	19	17	15	12	10	8	5	2
US 103 ES/DS/HES		28	26	23	21	19	17	15	12	10	8	5	2



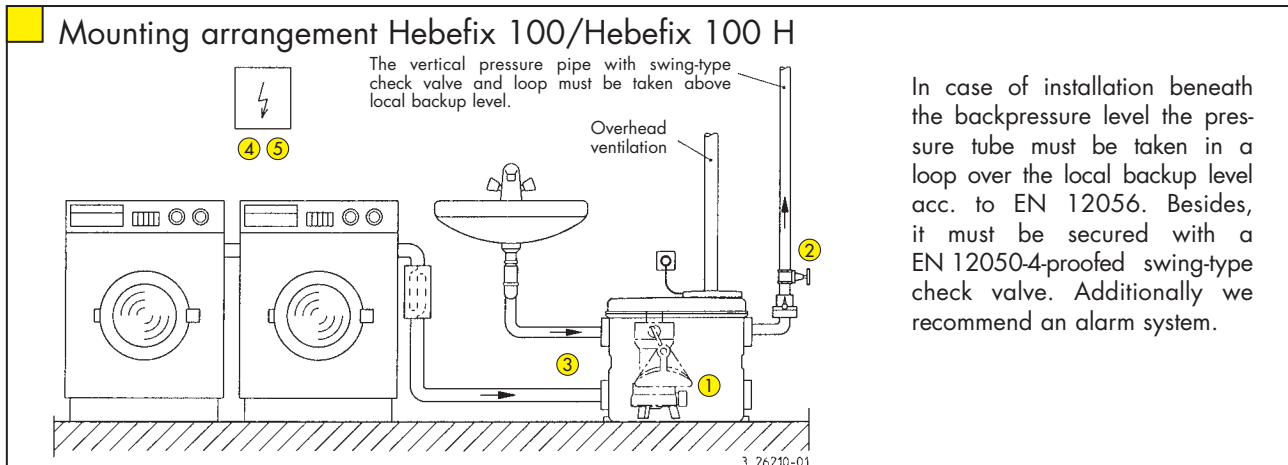

## Electrical data

Hebefix 100-tank selectable with type	Type of current	Voltage Volt	Motor rating kW		RPM min <sup>-1</sup>	F.L.C. Amp.	Motor-protection	Plug
			P <sub>1</sub>	P <sub>2</sub>				
U 3 KS NIRO	1-phase 1/N/PE~230		0,32	0,20	2720	1,4		safety-
U 3 KS spezial	1-phase 1/N/PE~230		0,32	0,20	2720	1,4		safety-
U 5 KS NIRO	1-phase 1/N/PE~230		0,52	0,38	2716	2,3		safety-
U 6 K NIRO ES	1-phase 1/N/PE~230		0,70	0,45	2600	3,4		safety-
U 6 K NIRO DS	3-phase 3/PE~400		0,75	0,58	2750	1,3		CEE-
US 62 ES	1-phase 1/N/PE~230		0,83	0,50	2500	3,9		safety-
US 62 DS	3-phase 3/PE~400		0,85	0,60	2800	1,4	Built-in	CEE-
US 73 ES/HES	1-phase 1/N/PE~230		0,83	0,50	2500	3,9	winding	safety-
US 73 DS	3-phase 3/PE~400		0,85	0,60	2800	1,4	thermostats	CEE-
US 102 ES	1-phase 1/N/PE~230		1,37	0,98	2700	6,0		safety-
US 102 DS	3-phase 3/PE~400		1,36	1,06	2740	2,4		CEE-
US 103 ES/HES	1-phase 1/N/PE~230		1,37	0,98	2700	6,0		safety-
US 103 DS	3-phase 3/PE~400		1,36	1,06	2740	2,4		CEE-

## Mounting arrangement Hebefix 100/Hebefix 100 H

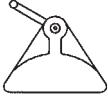
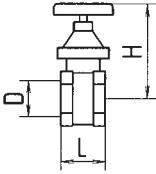

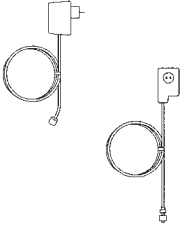
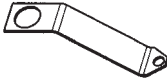
## Accessories

	Code No.	Hebefix 100	Hebefix 100 H						
 <p>① <b>Special float</b> for low switching points</p>	17424	●	●						
 <p>② <b>Stop valve</b>, 1½" (DN 40), PN 16</p> <table border="1" style="margin-left: 20px;"> <tr> <td>H</td> <td>L</td> <td>D</td> </tr> <tr> <td>125</td> <td>max.60</td> <td>1½"</td> </tr> </table>	H	L	D	125	max.60	1½"	11837	●	●
H	L	D							
125	max.60	1½"							
 <p>③ <b>Gromit</b> DN 100, elastic sleeve with hose band clamp</p>	27736	●	●						
 <p>④ <b>Alarm system</b>, mainsdependent, with volt-free contact</p> <p><b>Alarm system for washing machines AWR 3</b> with reed switch, separate, mains operated, 3 m cable</p> <p><b>Alarm system for washing machines AWO</b> (Plug housing – for alarm forwarding in case of several washing machines)</p>	20198 25092 25233	● ● ●	● ● ●						
 <p><b>Fastener</b> for alarm system (only U 3 KS and U 6 KS with special low level float)</p>	28191	●							
 <p>⑤ <b>Rechargeable battery</b> for off the line operation of the alarm system</p>	07562	●	●						

## Switching points

Types	Switching points ON	Switching points OFF
U 3 KS with standard float U 3 KS with special float	approx. 220 mm approx. 110 mm	approx. 115 mm approx. 50 mm
U 5 KS with standard float U 5 KS with special float	approx. 245 mm -	approx. 140 mm -
U 6 KS with standard float U 6 KS with special float	approx. 215 mm approx. 115 mm	approx. 115 mm approx. 50 mm
US 62 with standard float US 62 with special float	approx. 245 mm approx. 160 mm	approx. 130 mm approx. 110 mm
US 73 with standard float US 73 with special float	approx. 245 mm approx. 160 mm	approx. 130 mm approx. 110 mm
US 102 with standard float US 102 with special float	approx. 275 mm approx. 190 mm	approx. 160 mm approx. 140 mm
US 103 with standard float US 103 with special float	approx. 275 mm approx. 190 mm	approx. 160 mm approx. 140 mm

Switching points measured from the tank bottom.

## Technical data

### Tank

Water-tight PE tank (Hebefix 100 H PP-tank), approx. 75 ltr, with four combination connection branches for inlet DN 50/DN 100, tank venting, internal pump pressure branches and odour-sealed lid. The pressure piping can be passed watertight through the tank wall either towards the left or the right.

### Installation

The Hebefix 100 is an aboveground unit. The fixing kit required for installation are provided in the tank. The pump which has to be ordered separately, can be installed in the tank ready to be plugged in. The cable entry is suitable for all pumps used in conjunction with this system and supplied with rubber gland. It is not necessary to cut off the plug.

The lower additional inlets at both sides (H 100 mm) make it possible to connect the Hebefix 100 to a shower tray installed at floor level. The standard float of the U 3 KS NIRO/U 6 KS NIRO must then be replaced by the low level float for shower connection. (Please note when ordering!)

### Scope of supply

Plastic tank for application of a EN 12050 inspected pump with seal and cover, four combination inlets, collar DN 100, plug-in seals and flexible connection, tank venting, activated carbon filter (only Hebefix 100), pipe entry, internal tank pressure piping (in the case of Hebefix 100 H in stainless steel) and 1½" swing-type check valve, (without pump).

### Hebefix 100 H - duplex unit

By connecting 2 separate Hebefix 100 H a hot water duplex unit can be designed at site. The necessary accessories are available on request.

